

11

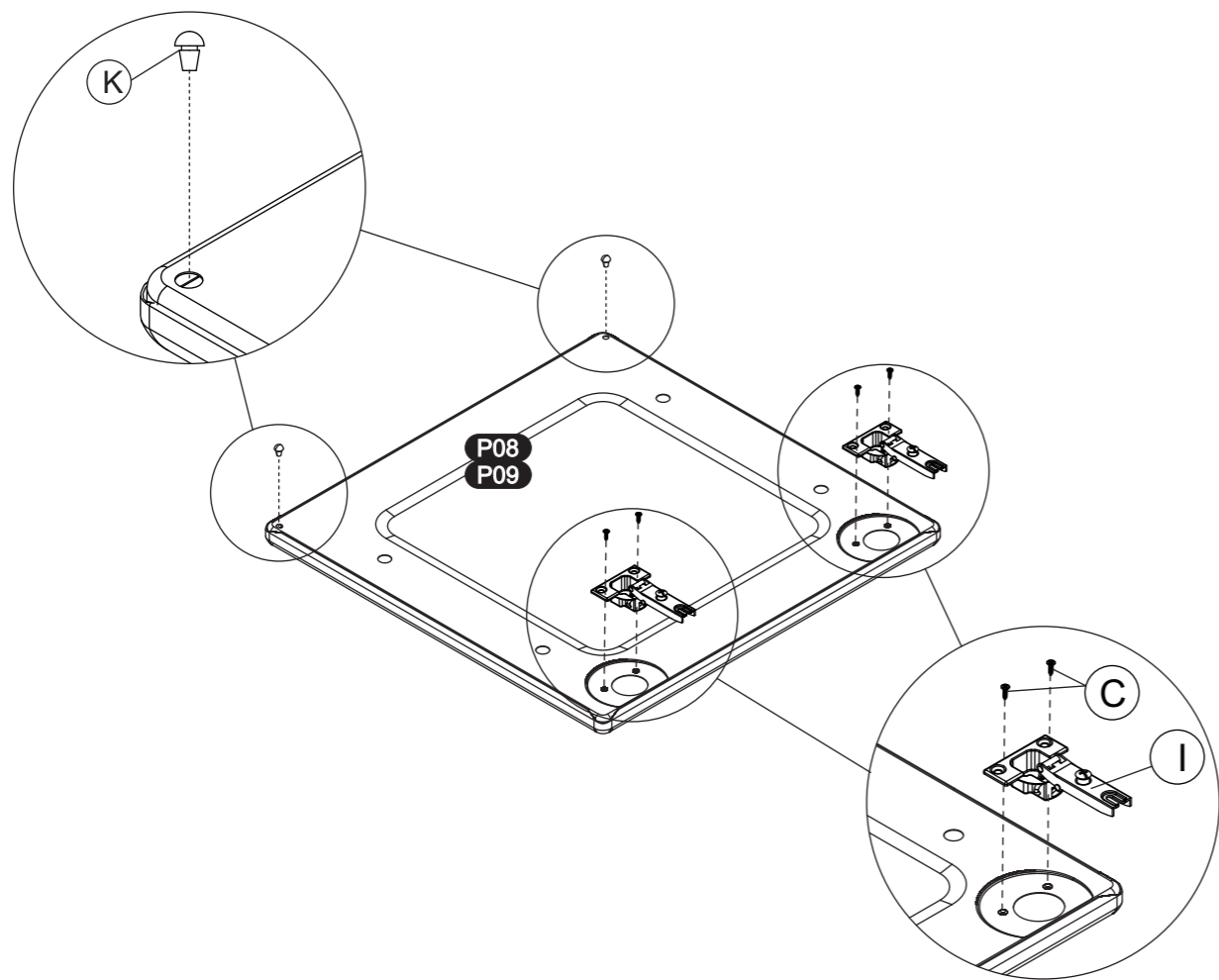

ATENÇÃO:
 -Ler e observar atentamente toda a instrução antes de iniciar a montagem.
 -Monte o móvel sobre uma forração, de preferência em cima de uma mesa.
 -Somente aperte os Parafusos após a montagem do móvel.
 -Observe que nas Laterais existe uma etiqueta de indicação.
ATTENTION:
 -Read the instructions carefully before starting the assembly
 -Assemble the cabinet on a carpet on top of a table if possible.
 -Fasten the screws only after the cabinet complete assembling.
 -Observe that there is an indication label on the side units.
ATENCIÓN:
 -Lea y fíjese atentamente en la esquemática de la ensamblaje, antes de armar el mueble
 -Arme el mueble sobre una superficie protegida, de preferencia arriba de una mesa.
 -Solamente apriete los Tornillos después del ensamblaje del mueble.
 -Fíjese que en la lateral existe una etiqueta que indica la dirección

Bertolini
 Armário Triplo Baixo 1050
 Triple Cabinet low 1050
 Armário Triple Bajo 1050



- P50 Lateral /Side Panel/Lateral
- P29 Base /Upper panel/Base
- P53 Fundo /Bottom/Fondo
- P08 Porta Direita /Right Door/Puerta Derecha
- P09 Porta Esquerda /Left Door/Puerta Izquierda
- P90 Coluneta /Column/Vigueta

Quantidade Quantity Cantidad
02
02
01
02
01
01

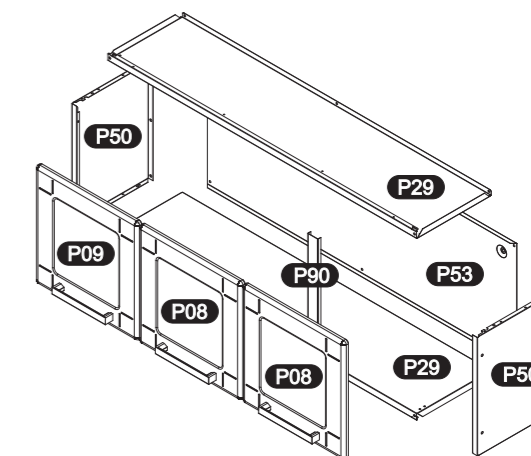

Ref:
6003

12

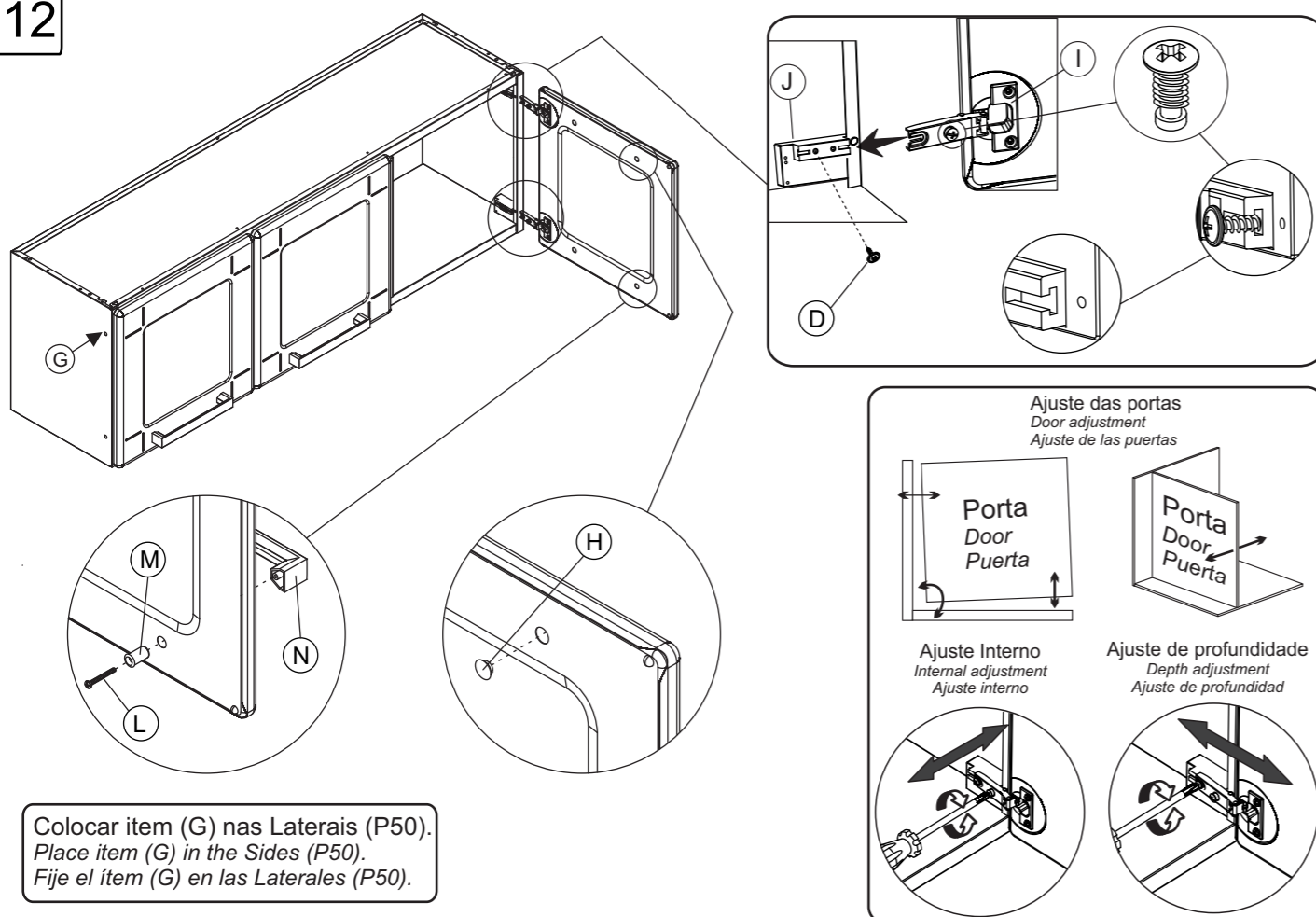

Colocar item (G) nas Laterais (P50).
 Place item (G) in the Sides (P50).
 Fije el ítem (G) en las Laterales (P50).

Bertolini Bertolini Bertolini Bertolini

Acessórios
Hardware
Accesorios

Quantidade
Quantity
Cantidad

Acessórios
Hardware
Accesorios

Quantidade
Quantity
Cantidad

A		Parafuso AA 4,8x45 Screw AA 4,8x45 Tornillo AA 4,8x45	02	L		Parafuso RI 3,5x25 Screw RI 3,5x25 Tornillo RI 3,5x25	06
B		Bucha S8 Bushing S8 Taco S8	02	M		Bucha Bushing Taco	06
C		Parafuso AA 4,2x9,5 Screw AA 4,2x9,5 Tornillo AA 4,2x9,5	12	N		Puxador Handle Tirador	06
D		Parafuso MP 3,5x10 Screw MP 3,5x10 Tornillo MP 3,5x10	24	O		Tapa furo Ø 3mm Hole cap Ø 3mm Tapa agujero Ø 3mm	04
E		Parafuso 3/16x5/16 Screw 3/16x5/16 Tornillo 3/16x5/16	07				
F		Porca 3/16 Nut 3/16 Tuerca 3/16	07				
G		Tapa furo Ø 6,5mm Hole cap Ø 6,5mm Tapa agujero Ø 6,5mm	04				
H		Tapa furo Ø 10mm Hole cap Ø 10mm Tapa agujero Ø 10mm	06				
I		Dobradiça Hinge Bisagra	06				
J		Calço Wedge Calce	06				
K		Amortecedor Shok-absorber Amortiguador	06				

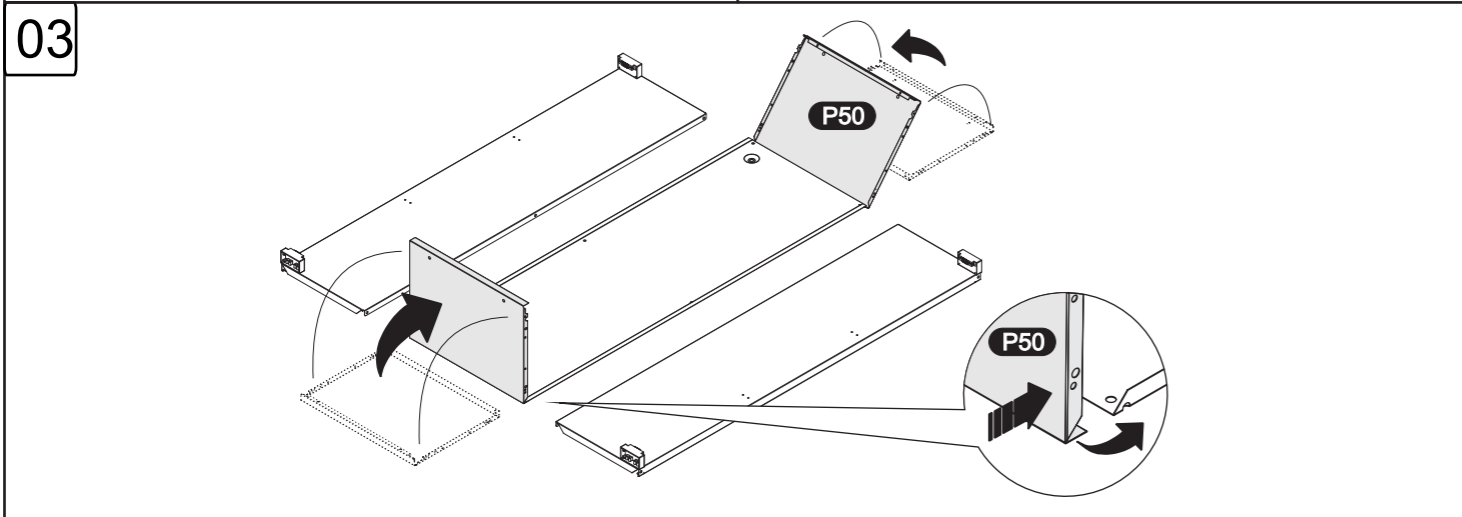
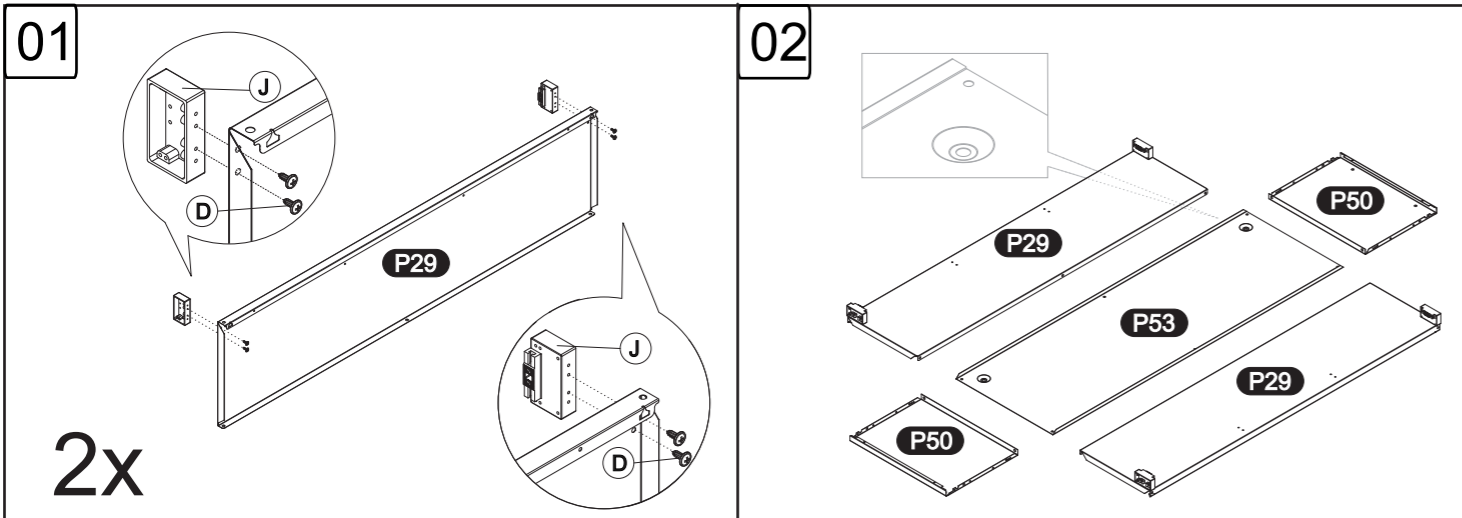

Bertolini Bertolini Bertolini Bertolini

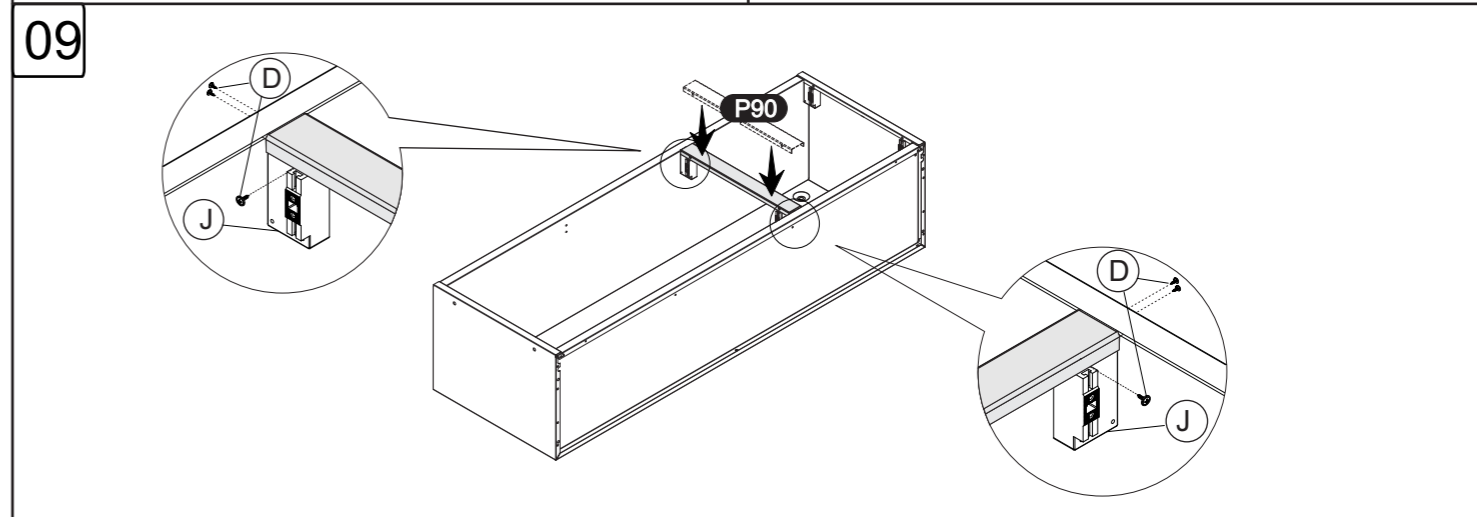
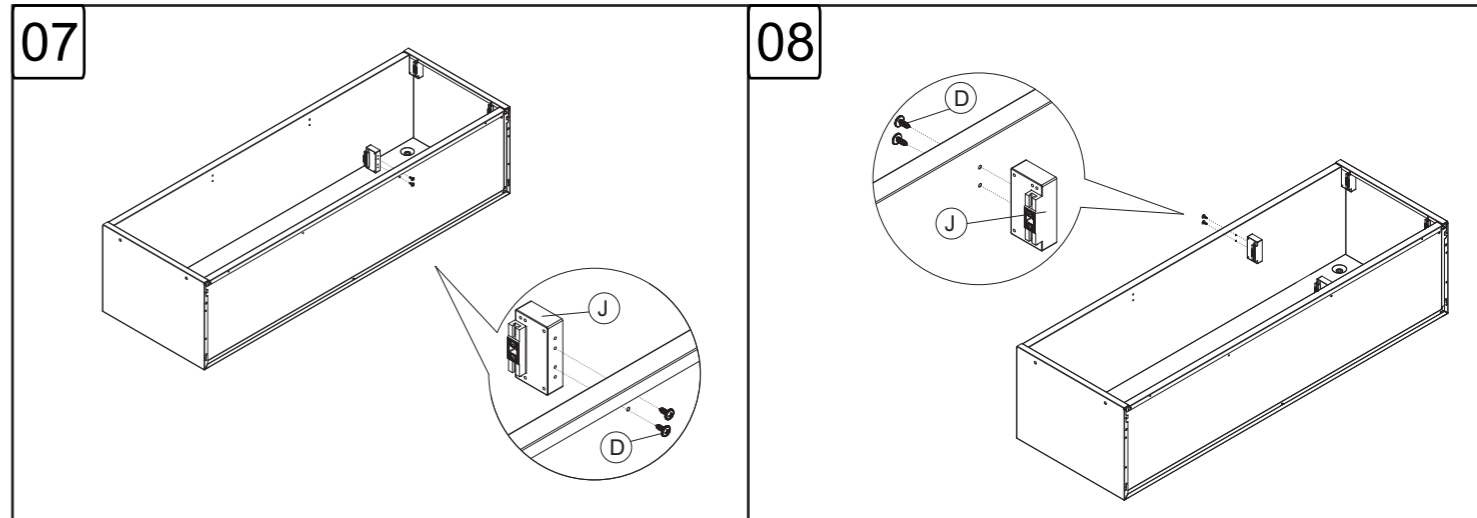
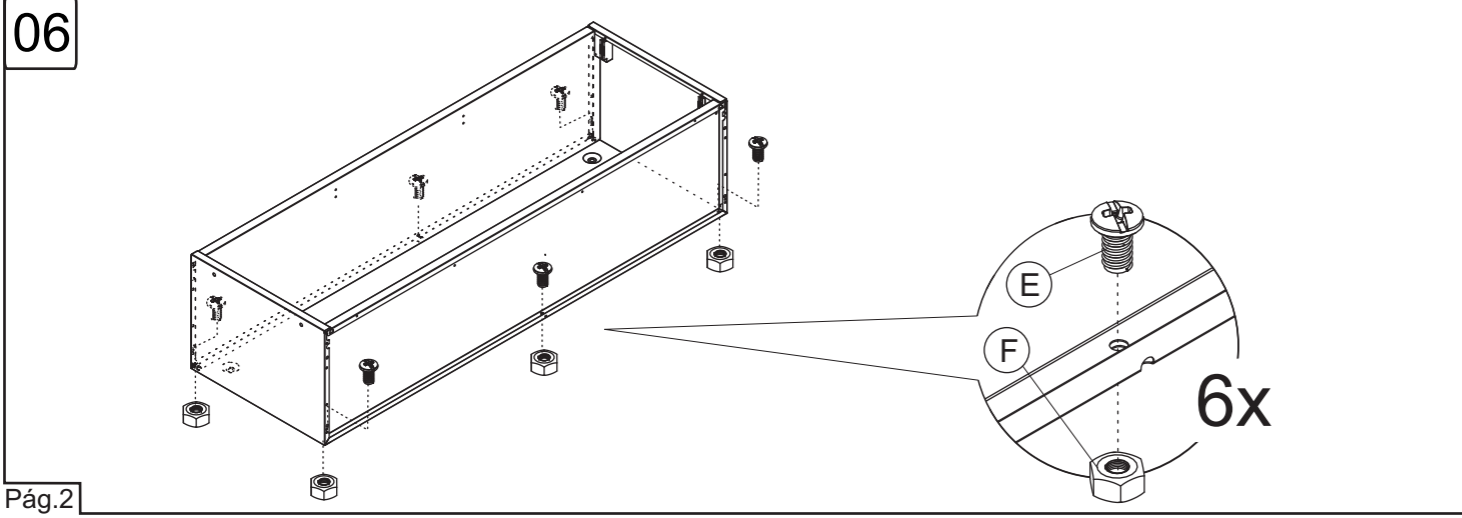
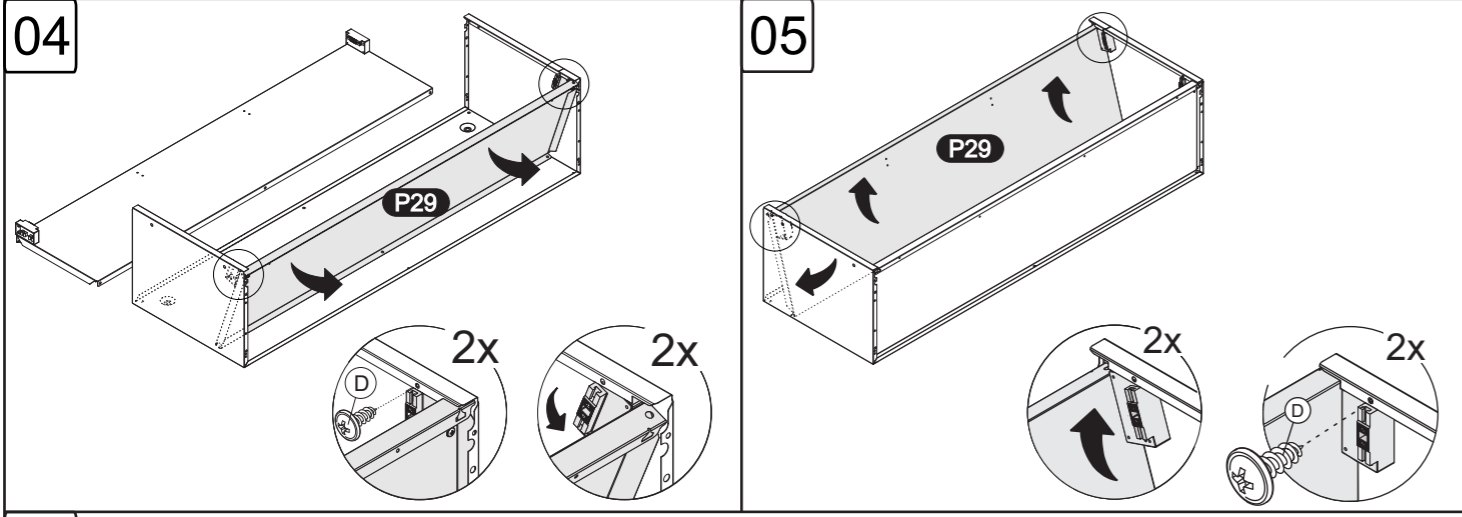

Bertolini Bertolini Bertolini Bertolini

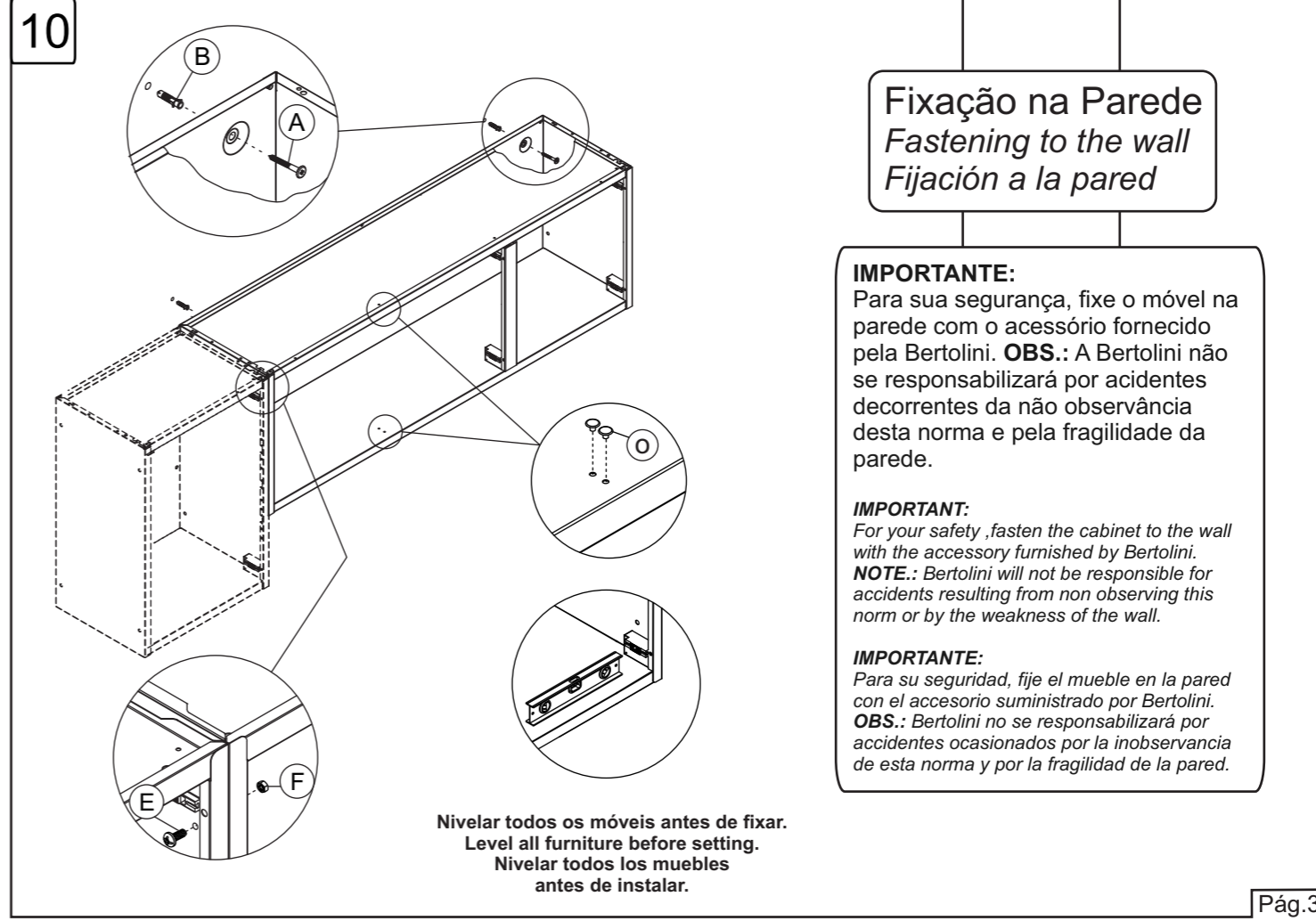

ATENÇÃO:
 -Ler e observar atentamente toda a instrução antes de iniciar a montagem.
 -Monte o móvel sobre uma forração, de preferência em cima de uma mesa.
 -Somente aperte os Parafusos após a montagem do móvel.
 -Observe que nas Laterais existe uma etiqueta de Indicação.

ATTENTION:
 -Read the instructions carefully before starting the assembly
 -Assemble the cabinet on a carpet on top of a table if possible.
 -Fasten the screws only after the cabinet complete assembling.
 -Observe that there is an indication label on the side units.

ATENCIÓN:
 -Lea y fíjese atentamente en la esquemática de la ensamble, antes de armar el mueble
 -Arme el mueble sobre una superficie protegida, de preferencia arriba de una mesa.
 -Solamente apriete los Tornillos después del ensamble del mueble.
 -Fíjese que en la lateral existe una etiqueta que indica la dirección

Bertolini

Nicho Superior Horizontal 700

Upper Horizontal Niche 700
 Nicho Superio Horizontal 700

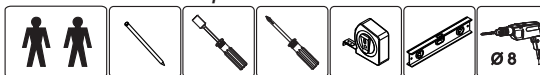

Quantidade
 Quantity
 Cantidad

- 1 Lateral /Side Panel/Lateral
- 2 Base / Base Panel/Base
- 3 Fundo /Bottom/Fondo

02
 02
 01

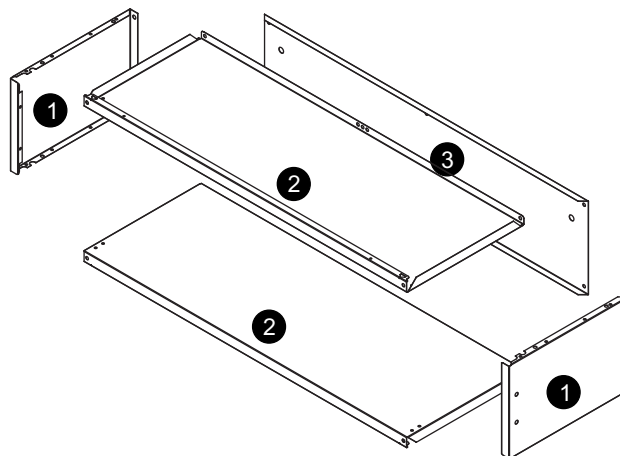

Ref:

601131

TIPLA MÚTIPLA MÚTIPLA MÚTIPLA

Acessórios
 Hardware
 Accesorios

Quantidade
 Quantity
 Cantidad

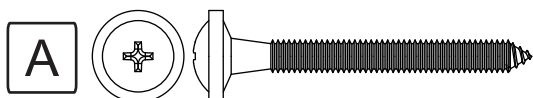

Parafuso AA 4,8x45
 Screw AA 4,8x45
 Tornillo AA 4,8x45

02

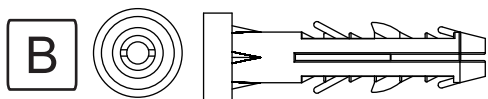

Bucha de fixação 8mm C/ Cab.
 Fastening bushing 8mm C/ Cab.
 Taco de fijación 8mm C/ Cab.

02



Parafuso 3/16x5/16
 Screw 3/16x5/16
 Tornillo 3/16x5/16

07



Porca 3/16
 Nut 3/16
 Tuerca 3/16

07



Tapa furo
 Hole cap
 Tapa agujero

04



Parafuso MP 3,5x10
 Screw MP 3,5x10
 Tornillo MP 3,5x10

08

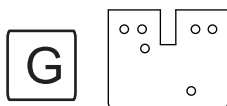

Calço
 Wedge
 Calce

04

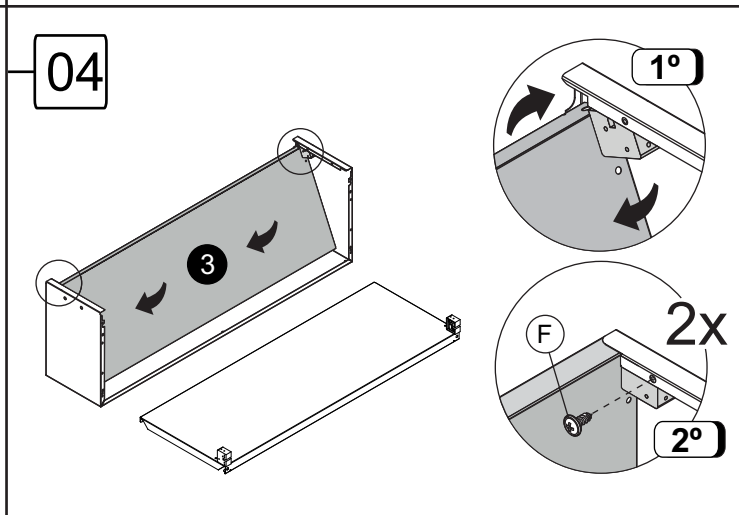
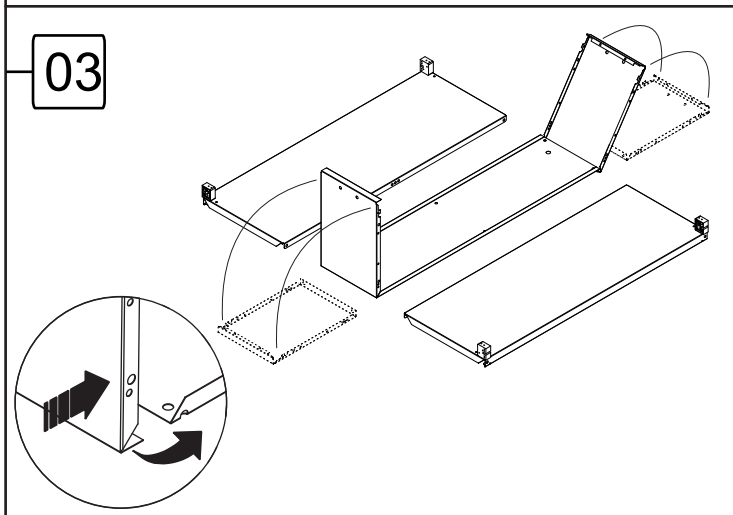
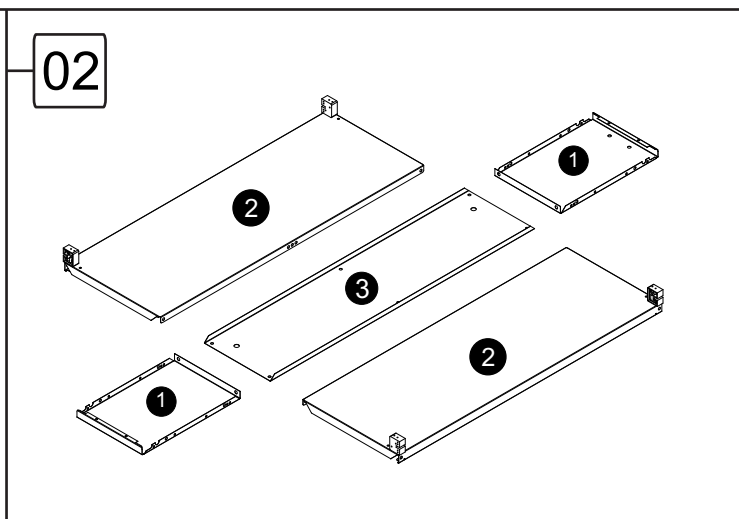
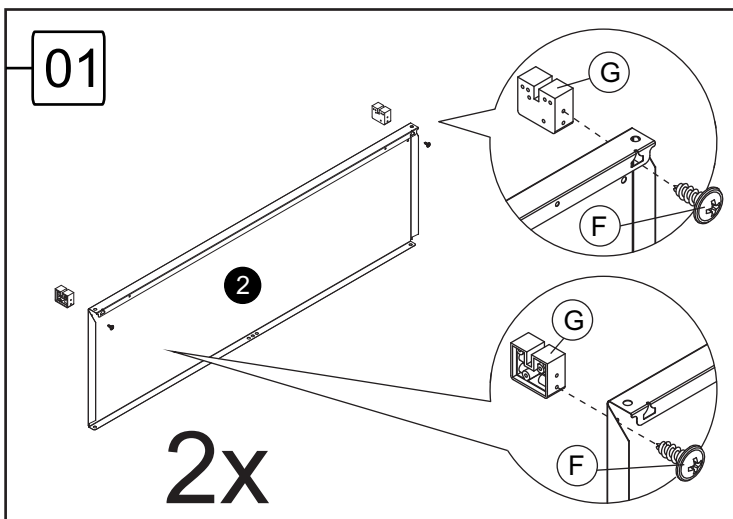

TIPLA MÚLTIPLA MÚLTIPLA MÚLTIPLA

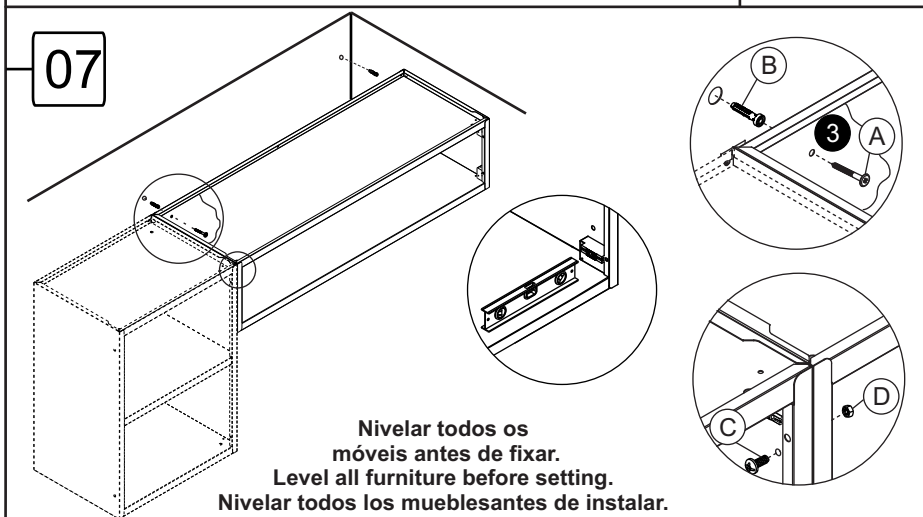
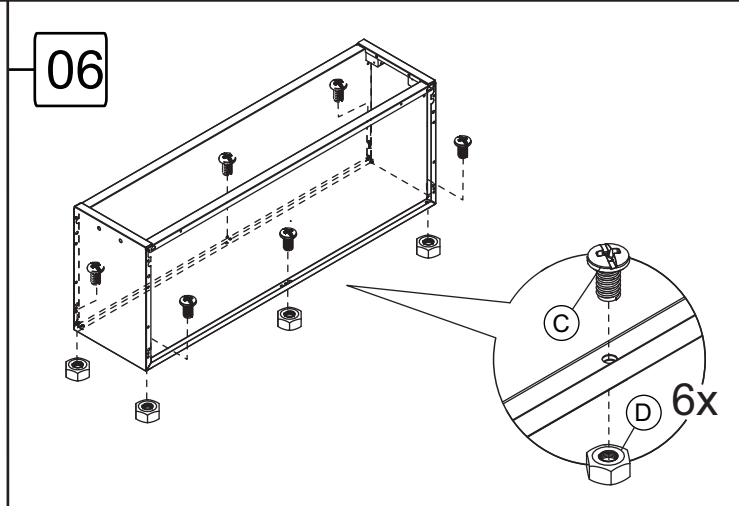
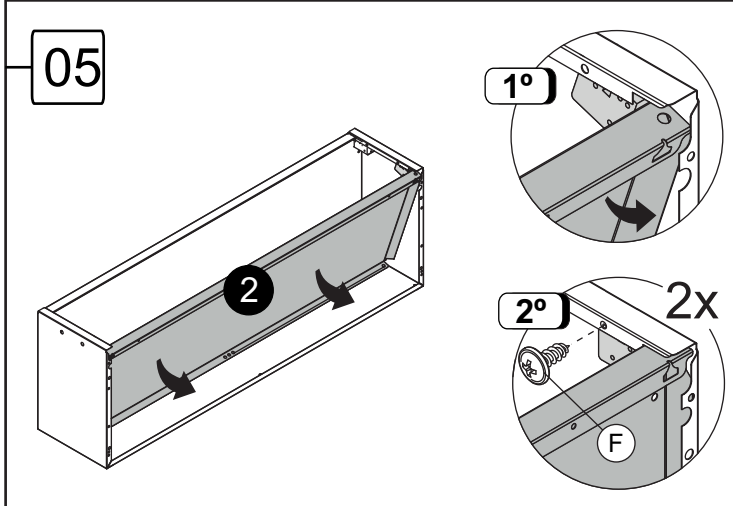

Fixação na Parede
Fastening to the wall
Fijación a la pared

IMPORTANTE:
Para sua segurança, fixe o móvel na parede com o acessório fornecido pela Bertolini. **OBS.:** A Bertolini não se responsabilizará por acidentes decorrentes da não observância desta norma e pela fragilidade da parede.

IMPORTANT:
For your safety, fasten the cabinet to the wall with the accessory furnished by Bertolini. **NOTE.:** Bertolini will not be responsible for accidents resulting from non observing this norm or by the weakness of the wall.

IMPORTANTE:
Para su seguridad, fije el mueble en la pared con el accesorio suministrado por Bertolini. **OBS.:** Bertolini no se responsabilizará por accidentes ocasionados por la inobservancia de esta norma y por la fragilidad de la pared.

Nivelar todos os móveis antes de fixar.
Level all furniture before setting.
Nivelar todos los muebles antes de instalar.

16

Fixação na Parede
Fastening to the wall
Fijación a la pared

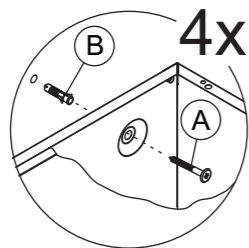
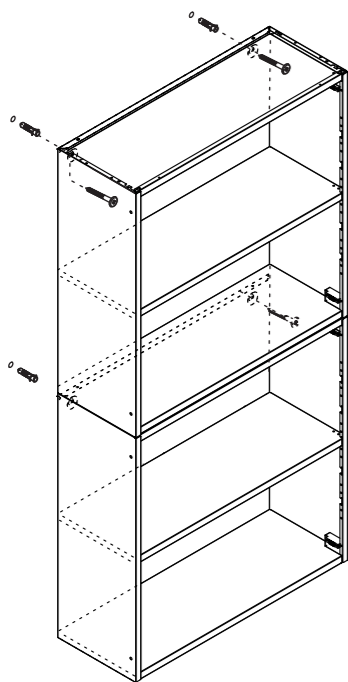

IMPORTANTE:
Para sua segurança, fixe o móvel na parede com o acessório fornecido pela Bertolini. **OBS.:** A Bertolini não se responsabilizará por acidentes decorrentes da não observância desta norma e pela fragilidade da parede.

IMPORTANT:
For your safety, fasten the cabinet to the wall with the accessory furnished by Bertolini. **NOTE.:** Bertolini will not be responsible for accidents resulting from non observing this norm or by the weakness of the wall.

IMPORTANTE:
Para su seguridad, fije el mueble en la pared con el accesorio suministrado por Bertolini. **OBS.:** Bertolini no se responsabilizará por accidentes ocasionados por la inobservancia de esta norma y por la fragilidad de la pared.

Nivelar todos os móveis antes de fixar.
Level all furniture before setting.
Nivelar todos los muebles antes de instalar.

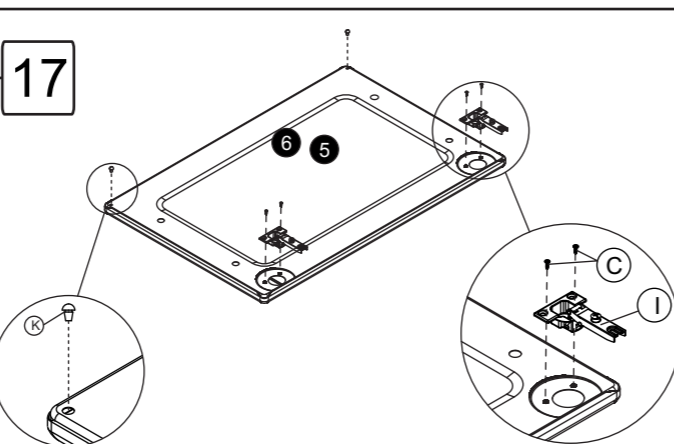

17

ATENÇÃO:
-Ler e observar atentamente toda a instrução antes de iniciar a montagem.
-Monte o móvel sobre uma forração, de preferência em cima de uma mesa.
-Somente aperte os Parafusos após a montagem do móvel.
-Observe que nas Laterais existe uma etiqueta de indicação.
ATTENTION:
-Read the instructions carefully before starting the assembly
-Assemble the cabinet on a carpet on top of a table if possible.
-Fasten the screws only after the cabinet complete assembling.
-Observe that there is an indication label on the side units.
ATENCIÓN:
-Lea y fíjese atentamente en la esquemática de la ensamblaje, antes de armar el mueble
-Arme el mueble sobre una superficie protegida, de preferencia arriba de una mesa.
-Solamente apriete los Tornillos después del ensamblaje del mueble.
-Fíjese que en la lateral existe una etiqueta que indica la dirección

Bertolini
Paneleiro 700 4Portas
Tall Cab.700 4Doors
Gabinete Vertical 700 4 Puertas.

- 1 Lateral Maior /Side Panel/Lateral
- 2 Base /Upper panel/Base
- 3 Fundo /Bottom/Fondo
- 4 Travessa /Crosspiece/Travesano
- 5 Porta Direita /Right Door/Puerta Derecha
- 6 Porta Esquerda /Left Door/Puerta Izquierda

Quantidade Quantity Cantidad
04
05
02
01
02
02

Ref:
CZDM13760
CZDM13761

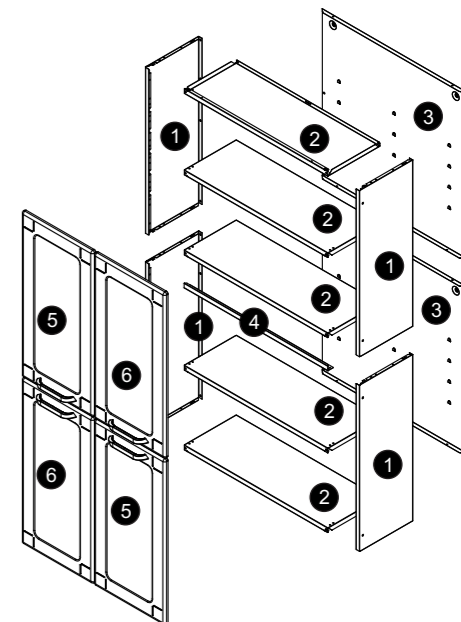

18

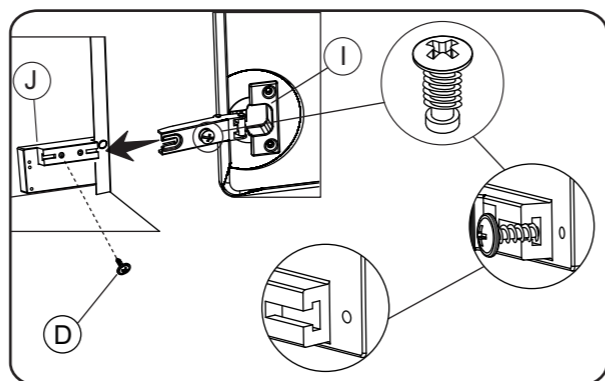
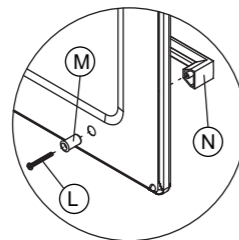
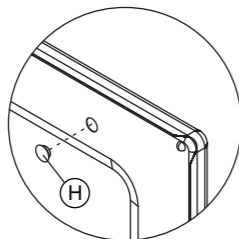
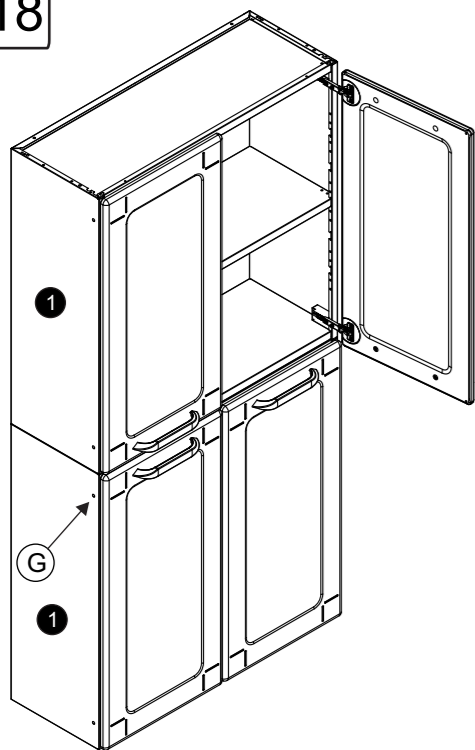

Ajuste das portas
Door adjustment
Ajuste de las puertas

Porta Door Puerta

Ajuste Interno
Internal adjustment
Ajuste interno

Ajuste de profundidade
Depth adjustment
Ajuste de profundidad

Colocar item (G) nas Laterais (1) e (2).
Place item (G) in the Sides (1) and (2).
Fije el ítem (G) en las Laterales (1) y (2).

Bertolini Bertolini Bertolini Bertolini

Acessórios
Hardware
Accesorios

Quantidade
Quantity
Cantidad

Acessórios
Hardware
Accesorios

Quantidade
Quantity
Cantidad

- A Parafuso AA 4,8x45
Screw AA 4,8x45
Tornillo AA 4,8x45
- B Bucha S8
Bushing S8
Taco S8
- C Parafuso AA 4,2x9,5
Screw AA 4,2x9,5
Tornillo AA 4,2x9,5
- D Parafuso MP 3,5x10
Screw MP 3,5x10
Tornillo MP 3,5x10
- E Parafuso 3/16x5/16
Screw 3/16x5/16
Tornillo 3/16x5/16
- F Porca 3/16
Nut 3/16
Tuerca 3/16
- G Tapa furo Ø 6,5mm
Hole cap Ø 6,5mm
Tapa agujero Ø 6,5mm
- H Tapa furo Ø 10mm
Hole cap Ø 10mm
Tapa agujero Ø 10mm
- I Dobradiça
Hinge
Bisagra
- J Calço
Wedge
Calce
- K Amortecedor
Shok-absorber
Amortiguador

- L Parafuso MP 3,5x30
Screw MP 3,5x30
Tornillo MP 3,5x30
- M Bucha
Bushing
Taco
- N Puxador
Handle
Tirador

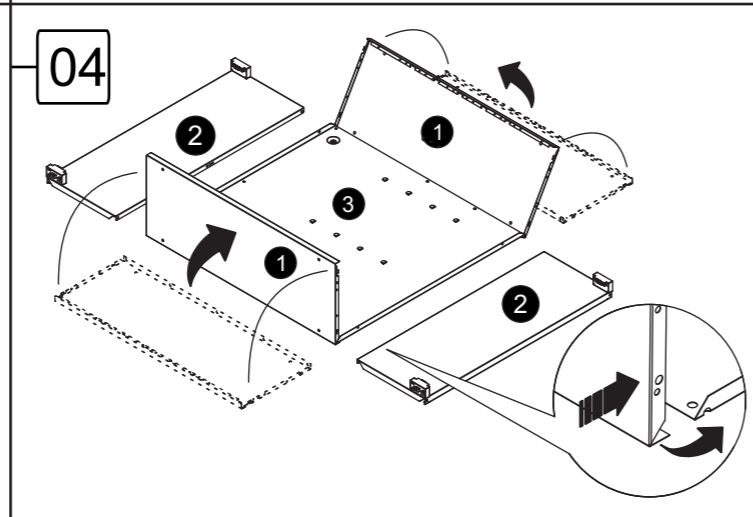
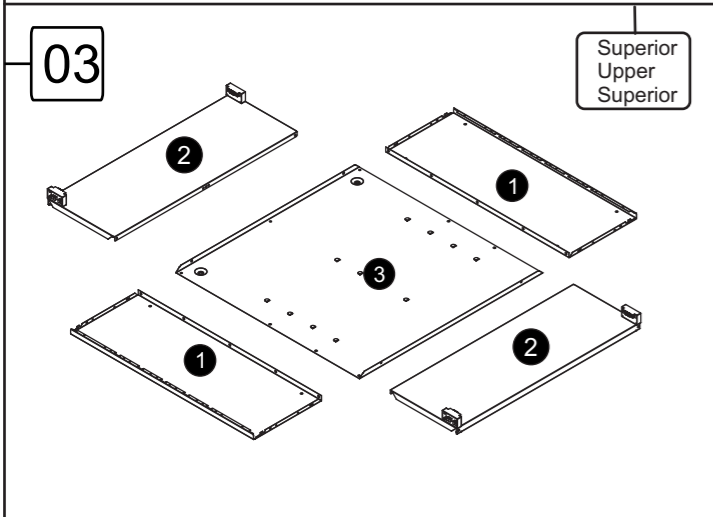
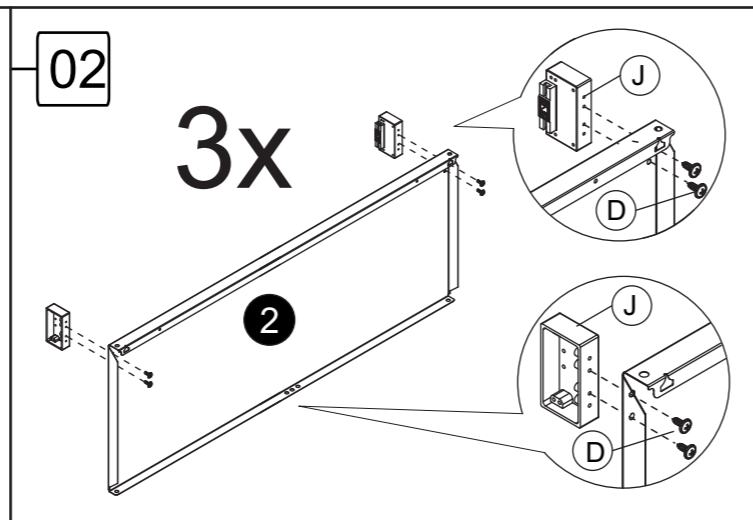
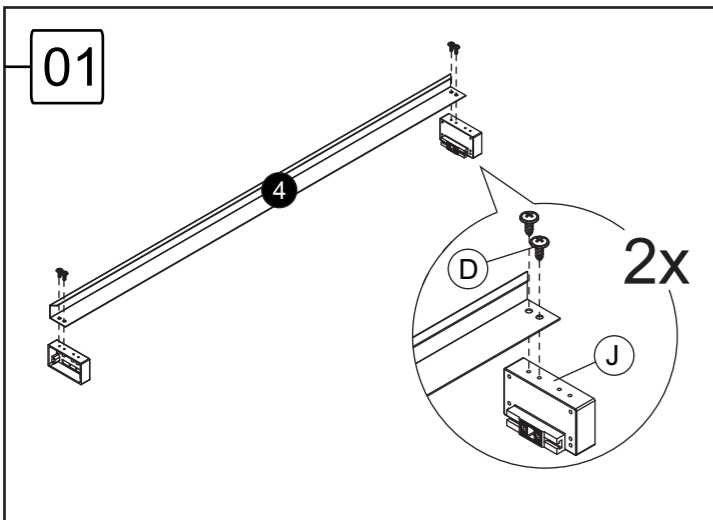

Bertolini Bertolini Bertolini Bertolini

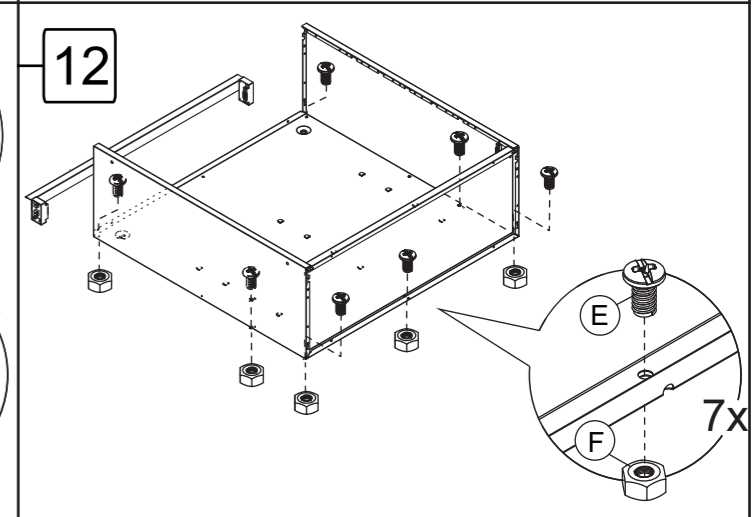
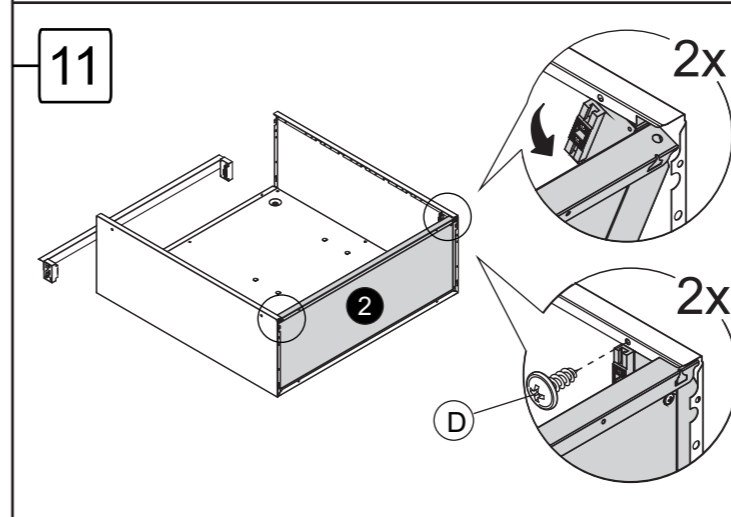
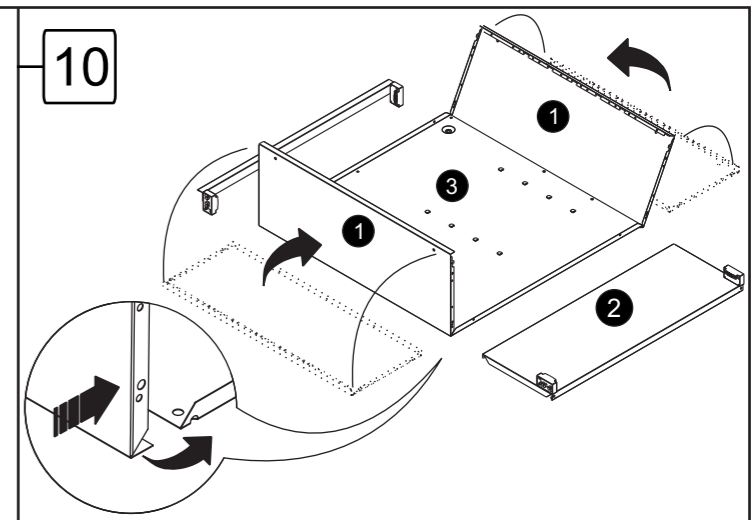
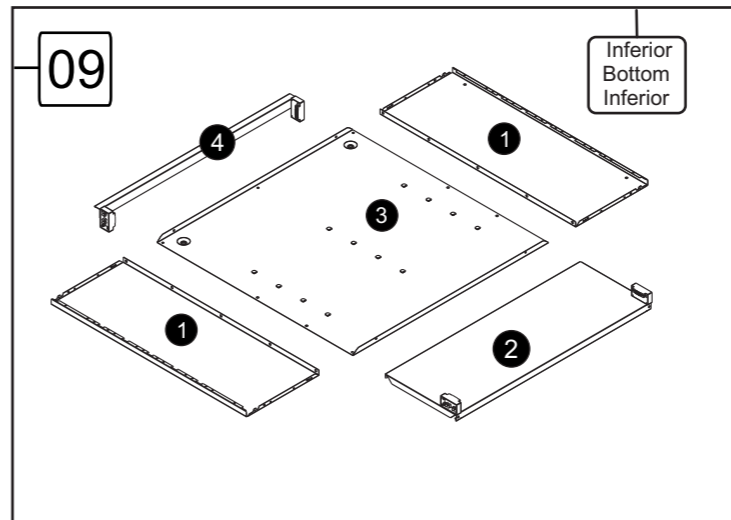
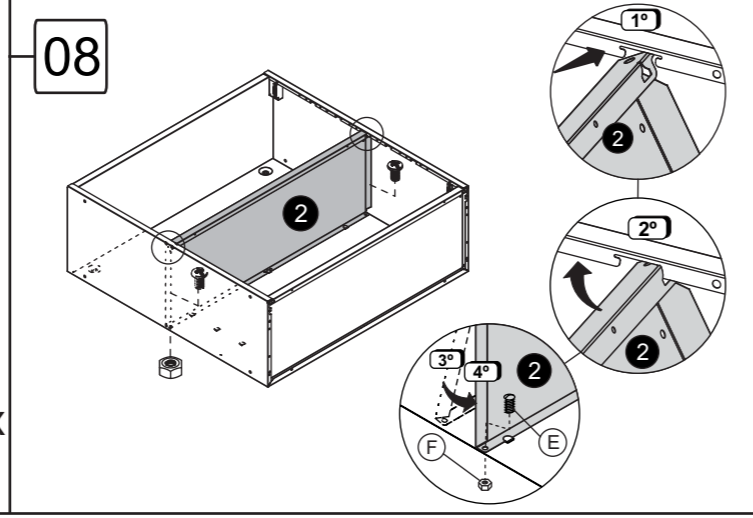
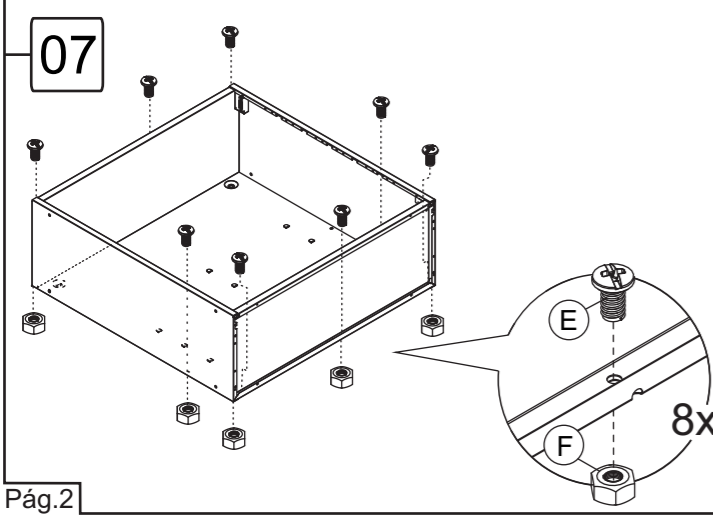
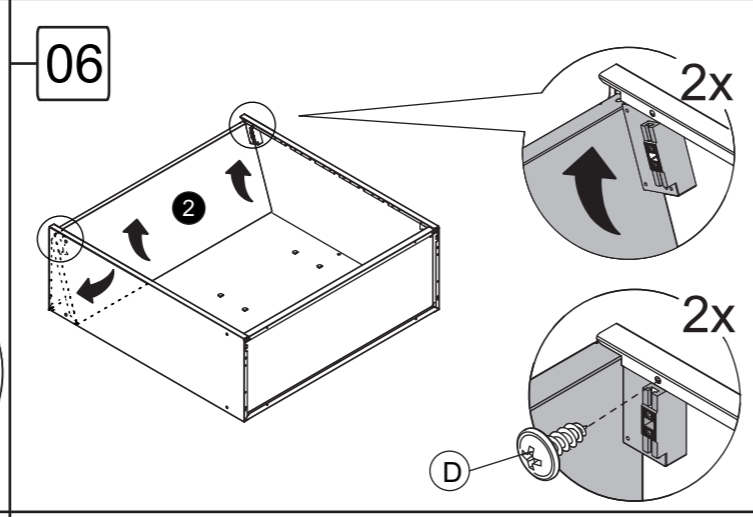
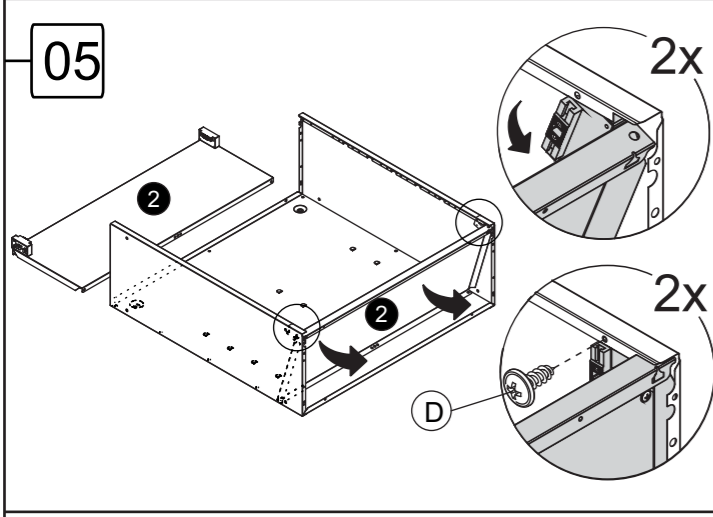

Bertolini Bertolini Bertolini Bertolini

