

# Bertolini

## Paneleiro 350/400

Tall Cab. 350/400

Gabinete 350/400

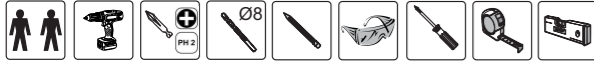

**ATENÇÃO:**  
 -Ler e observar atentamente toda a instrução antes de iniciar a montagem.  
 -Monte o móvel sobre uma forração, de preferência em cima de uma mesa.  
 -Somente aperte os Parafusos após a montagem do móvel.  
 -Observe que nas Laterais existe uma etiqueta de Indicação.

**ATTENTION:**  
 -Read the instructions carefully before starting the assembly  
 -Assemble the cabinet on a carpet on top of a table if possible.  
 -Fasten the screws only after the cabinet complete assembling.  
 -Observe that there is an indication label on the side units.

**ATENCIÓN:**  
 -Lea y fíjese atentamente en la esquemática de la ensamblaje, antes de armar el mueble  
 -Arme el mueble sobre una superficie protegida, de preferencia arriba de una mesa.  
 -Solamente apriete los Tornillos después del ensamblaje del mueble.  
 -Fíjese que en la lateral existe una etiqueta que indica la dirección

Códigos Codes Códigos	Itens Items Elementos	Quantidade Quantity Cantidad
P28	Lateral Maior /Side Panel/Lateral	02
P52	Lateral Menor/Side Panel/Lateral	02
P55	Base /Upper panel/Base	07
P61	Fundo /Bottom/Fondo	01
P54	Fundo Inferior/Bottom Inferior /Fondor Inferior	01
P63	Travessa /Crosspiece/Travesano	01
P12	Porta Direita /Right Door/Puerta Derecha	02
P25	Porta Direita Maior/Right Door Large/Puerta Derecha Mayor	01
P19	Suporte/Support/Soporte	04
P23	Pés /Legs/Patas	04

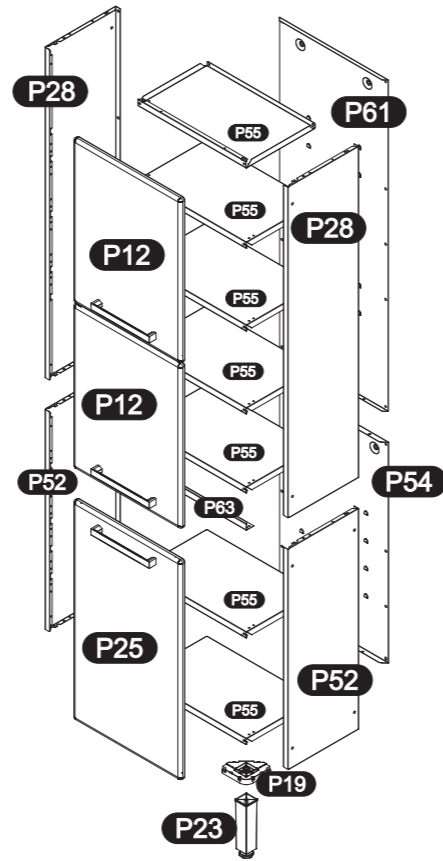

Ref:

6030 - 6031 - 6032 - 6033  
 7030 - 7031 - 7032 - 7033

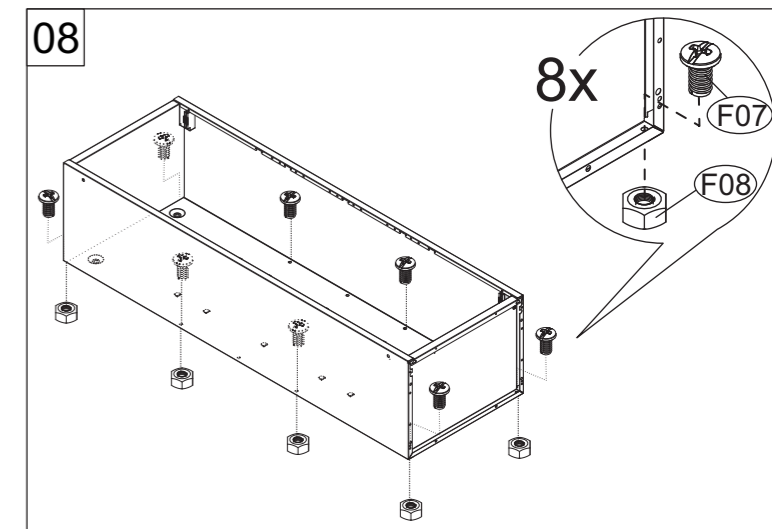
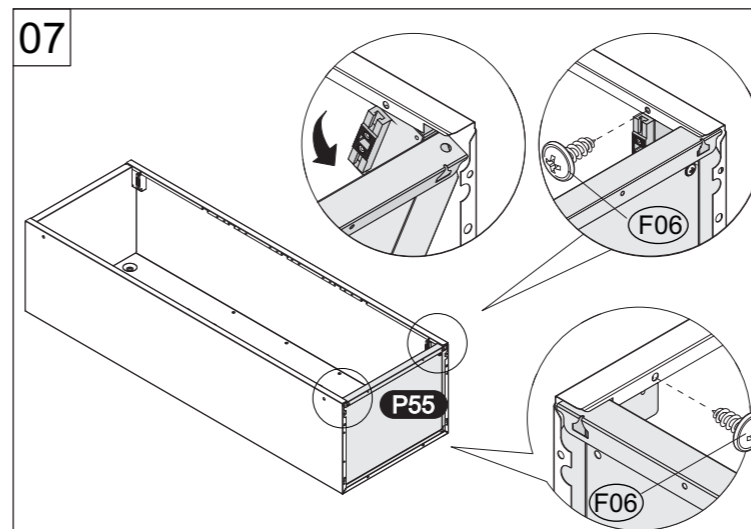
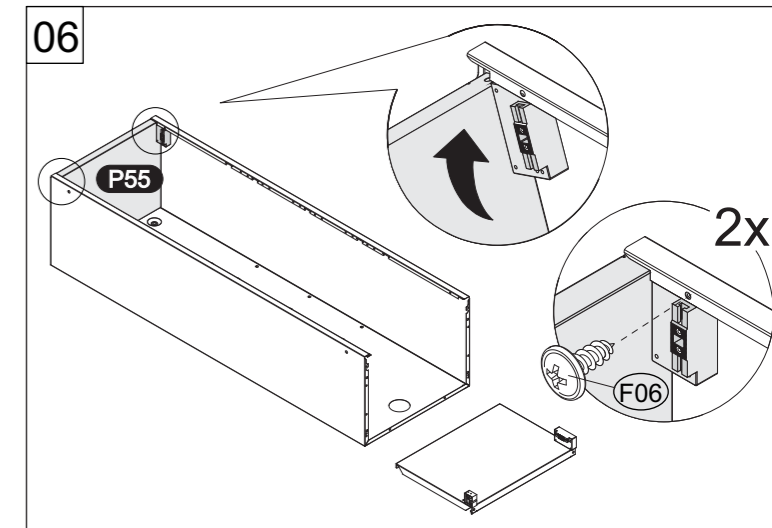
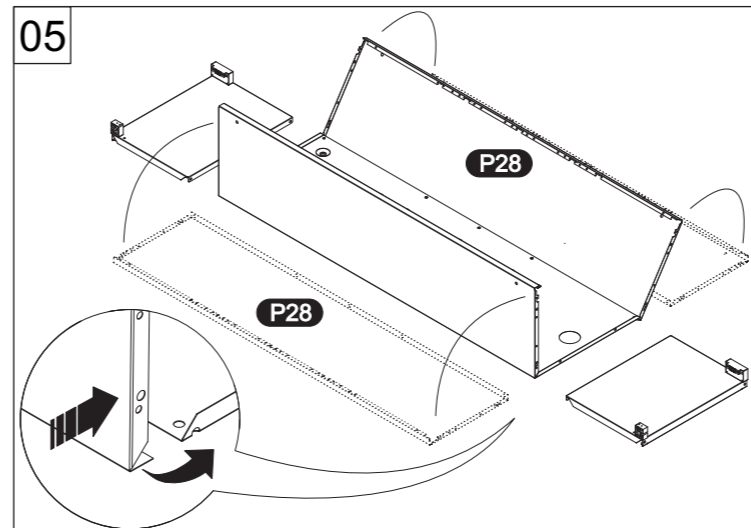
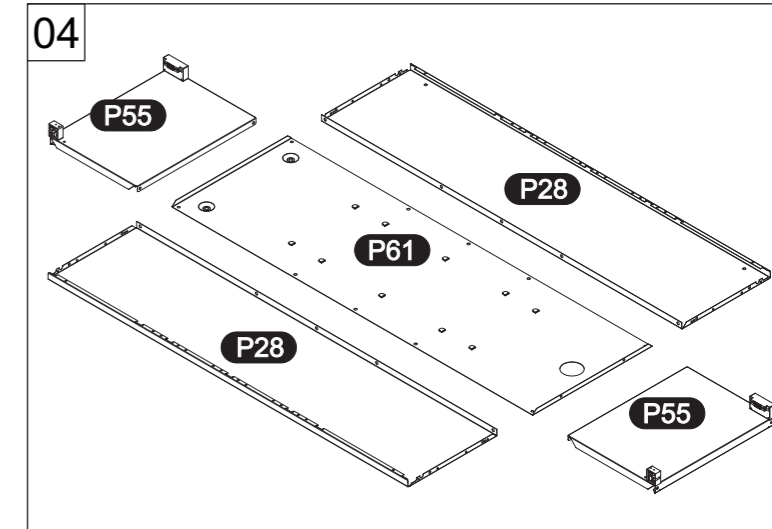
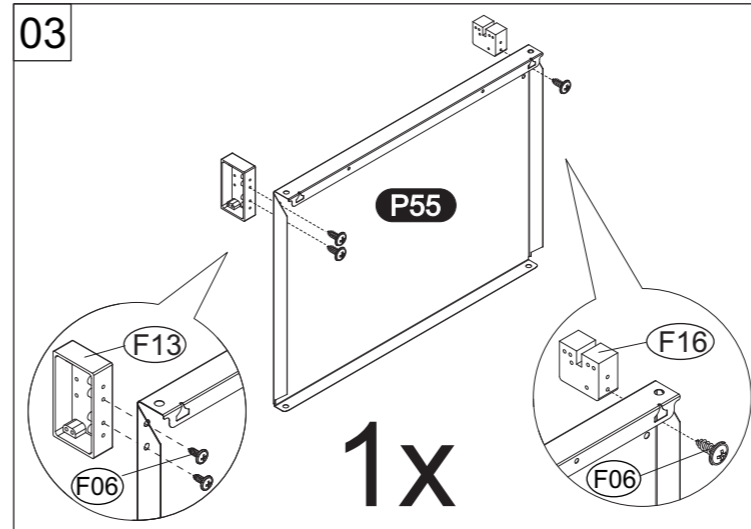
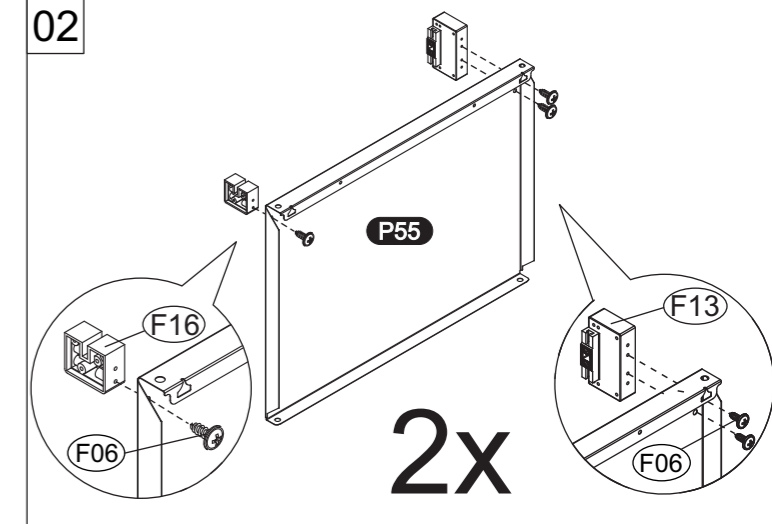
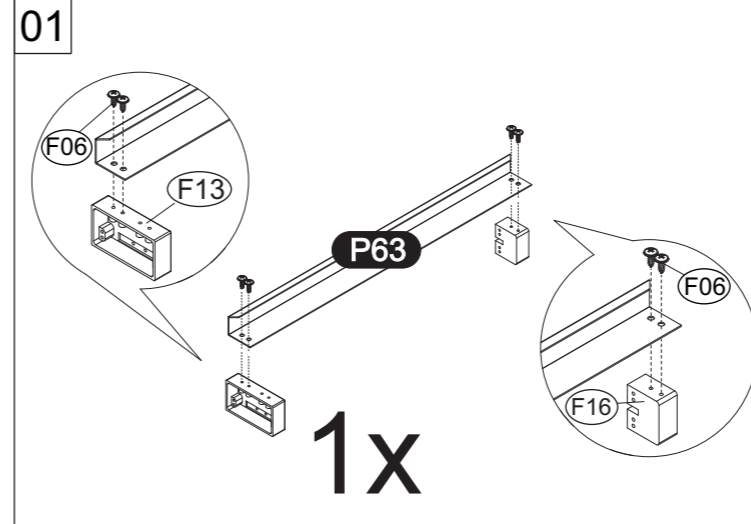

Acessórios Hardware Accesorios	Quantidade Quantity Cantidad	Acessórios Hardware Accesorios	Quantidade Quantity Cantidad
F01	Parafuso AA 4,8x45 Screw AA 4,8x45 Tornillo AA 4,8x45	F21	Amortecedor Shok-absorber Amortiguador
F02	Bucha S8 Bushing S8 Taco S8	F10	Parafuso RI 3,5x25 Screw RI 3,5x25 Tornillo RI 3,5x25
F09	Parafuso AA 4,2x9,5 Screw AA 4,2x9,5 Tornillo AA 4,2x9,5	F11	Bucha Bushing Taco
F06	Parafuso MP 3,5x10 Screw MP 3,5x10 Tornillo MP 3,5x10	F25	Puxador Handle Tirador
F07	Parafuso 3/16x5/16 Screw 3/16x5/16 Tornillo 3/16x5/16	F16	Calço Wedge Calce
F08	Porca 3/16 Nut 3/16 Tuerca 3/16		
F19	Tapa furo Ø 6,5mm Hole cap Ø 6,5mm Tapa agujeroØ 6,5mm		
F20	Tapa furo Ø 10mm Hole cap Ø 10mm Tapa agujero Ø 10mm		
F23	Dobradiça Hinge Bisagra		
F13	Calço Wedge Calce		
F15	Calço Wedge Calce		

**Importante!** Atentar para o sentido dos acessórios J, K e P para determinar a abertura da porta. O modelo a ser exemplificado nessa montagem é referente ao Cód.(6030,6031, 7030 e 7032) abertura das portas para a DIREITA. Para portas ESQUERDAS Cód.(6032, 6033, 7031 e 7033),teve-se inverter os acessórios.

**Important!** Pay attention to the direction of accessories J, K and P to determine the opening of the door. The model to be exemplified in this assembly is Referent end the Code(6030,6031, 7030 end 7032) door opening to the RIGHT. For LEFT doors code(6032, 6033, 7031 and 7033) reverse the accessories.

**Importante!** Atención a la posición de los accesorios J, K y P para determinar la apertura de la puerta. El modelo que se ejemplificará en este ensamblaje es referencial el Cod.(6030, 6031, 7030 y 7032) que se abre hacia la DERECHA. Para puertas IZQUIERDA Cod.(6032, 6033, 7031 y 7033) invierta los accesorios.



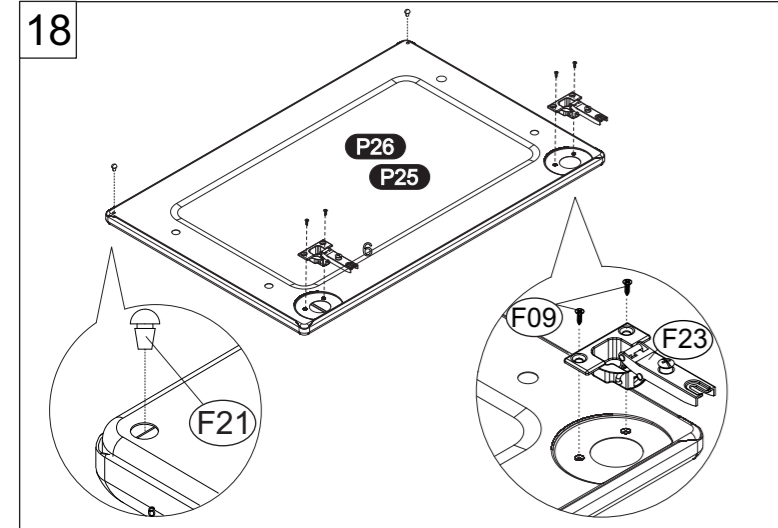
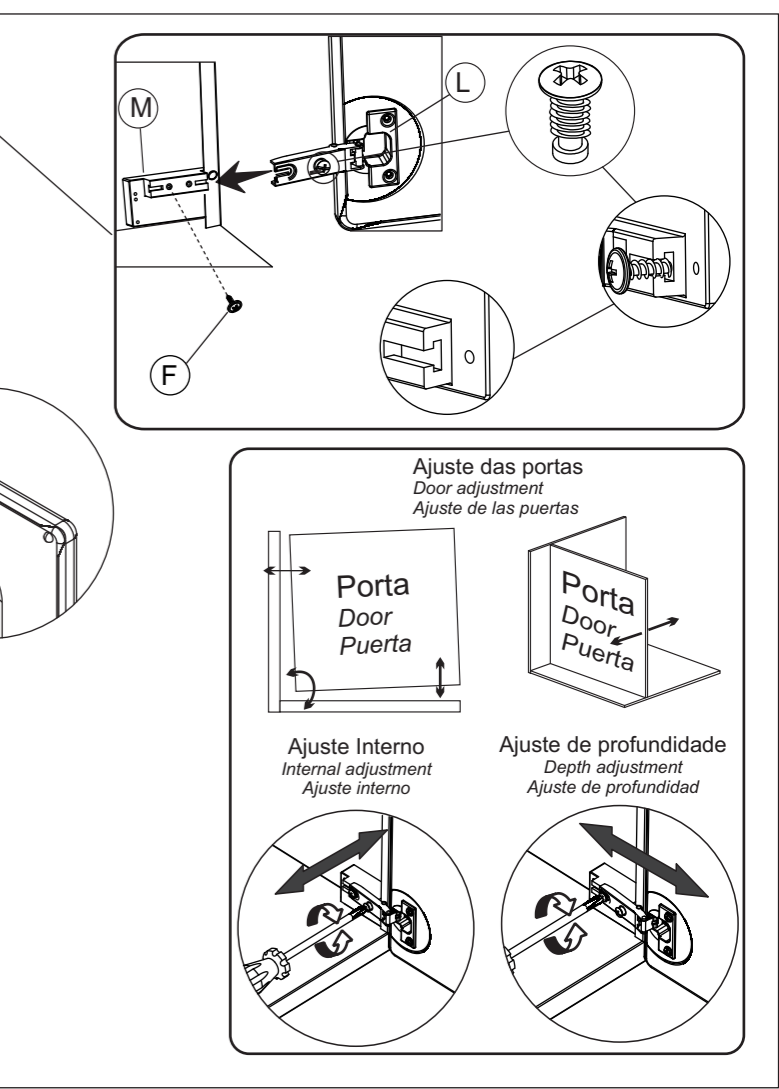
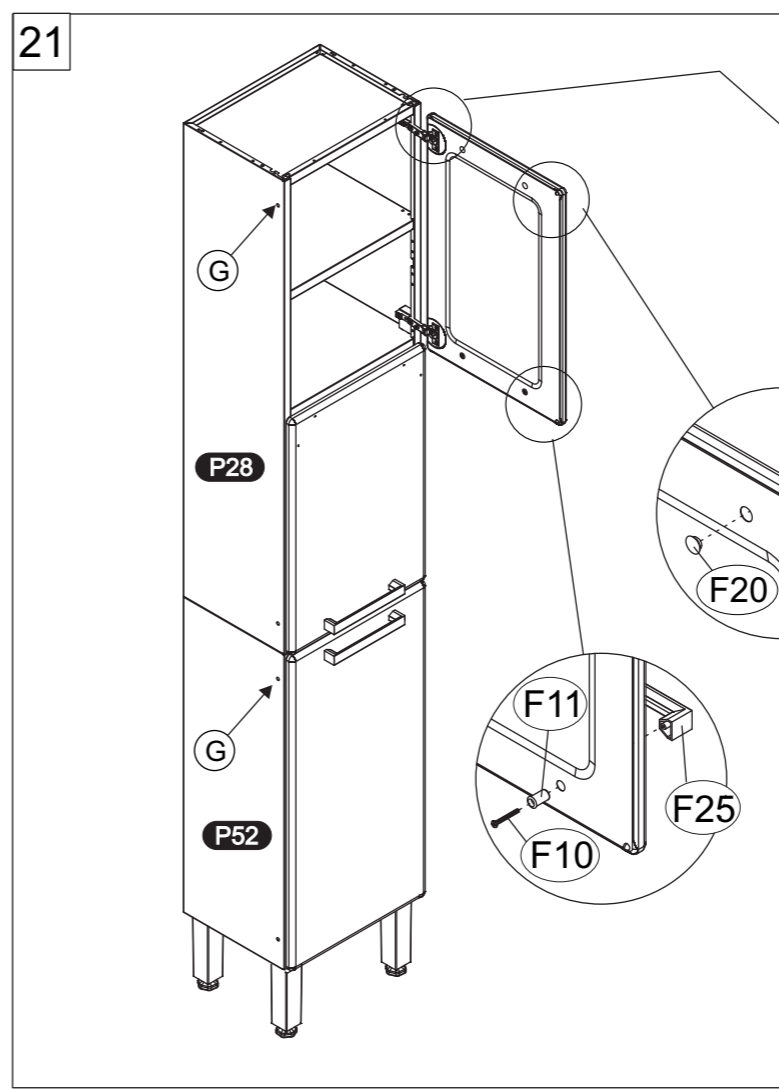
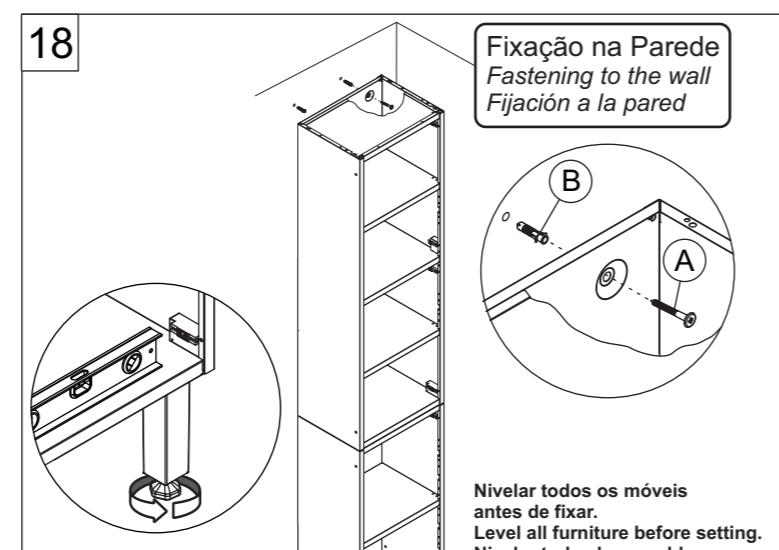
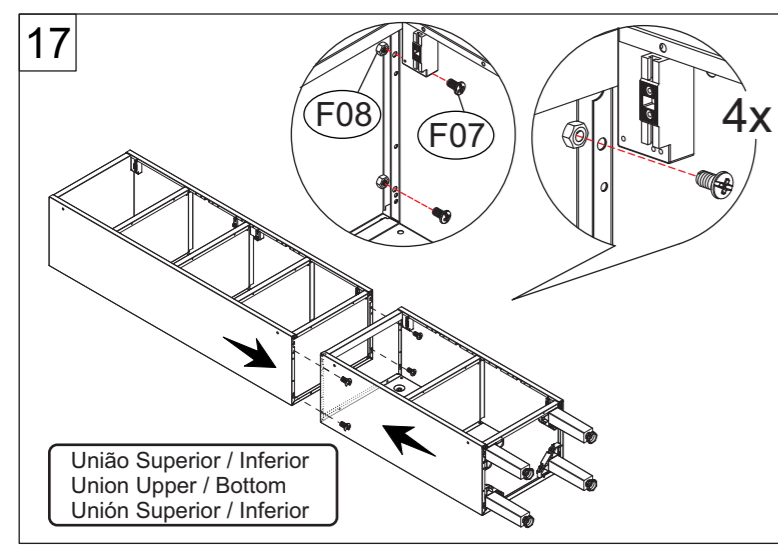
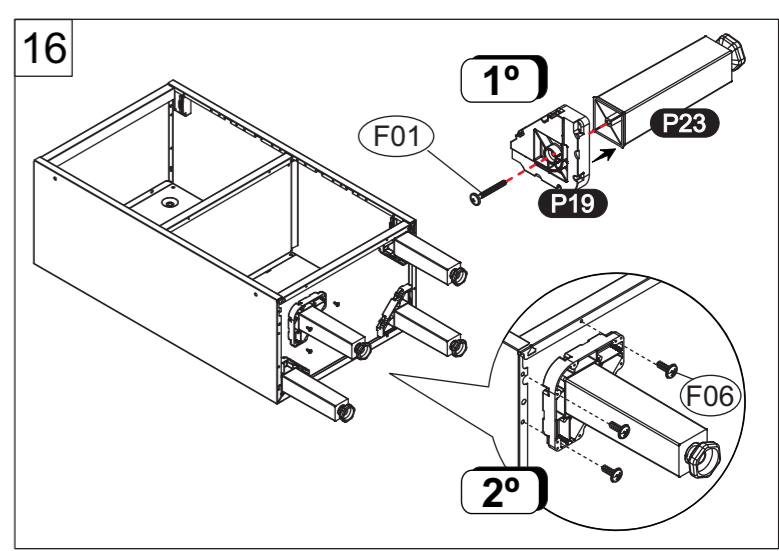
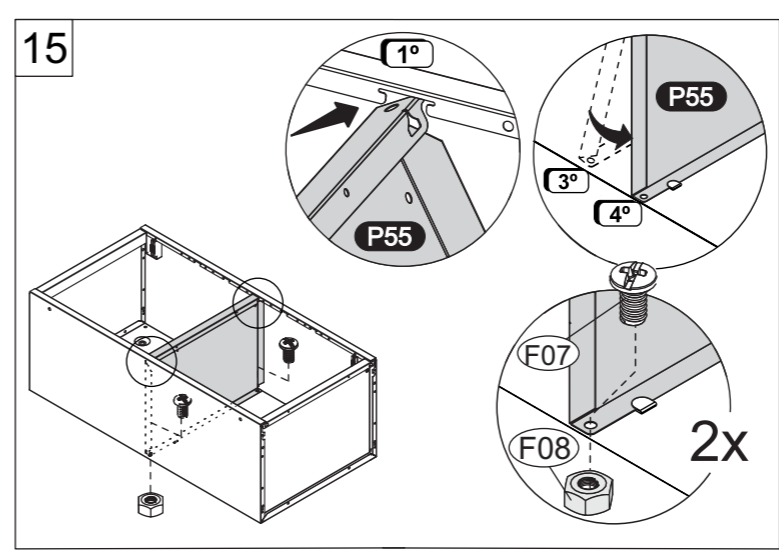
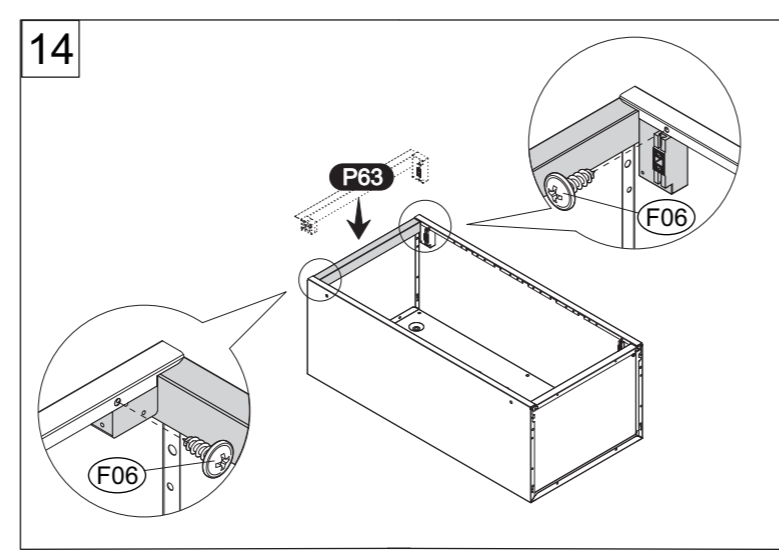
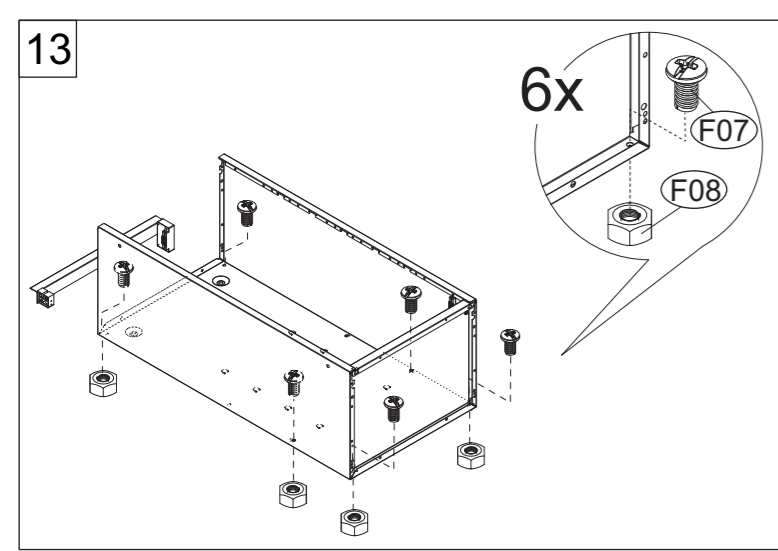
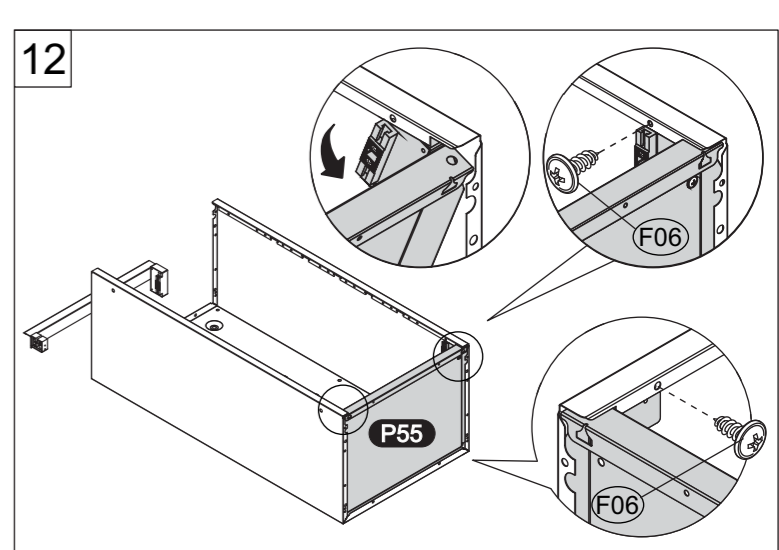
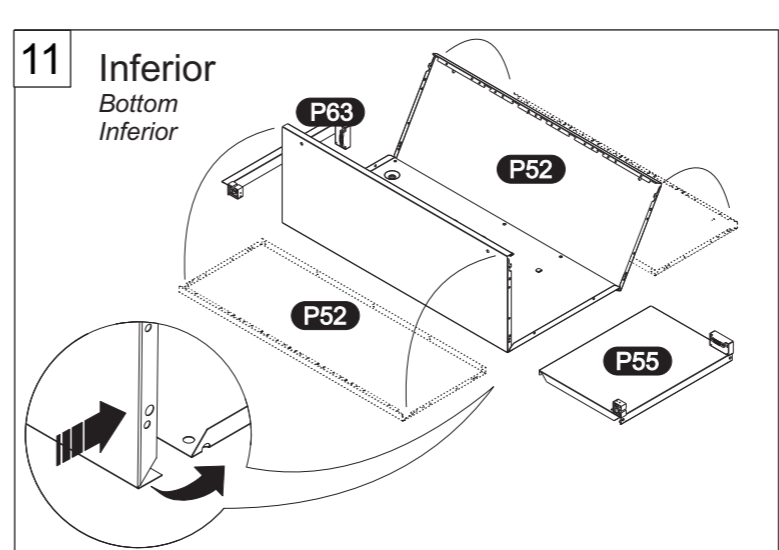
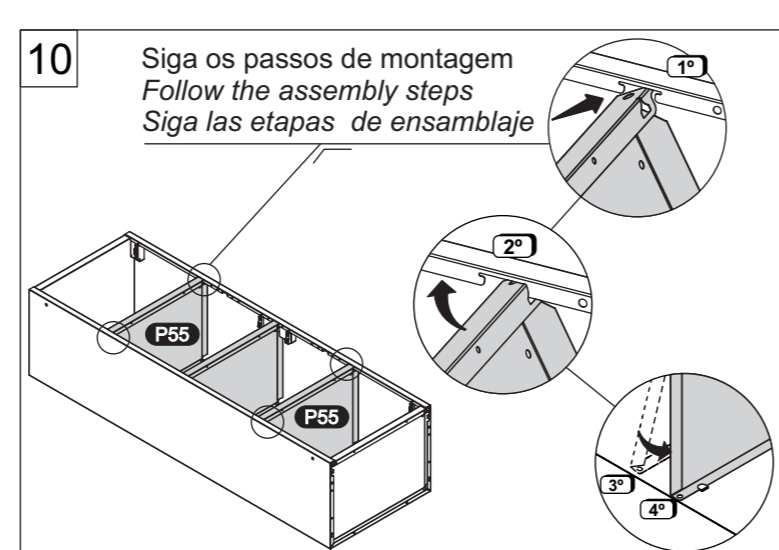
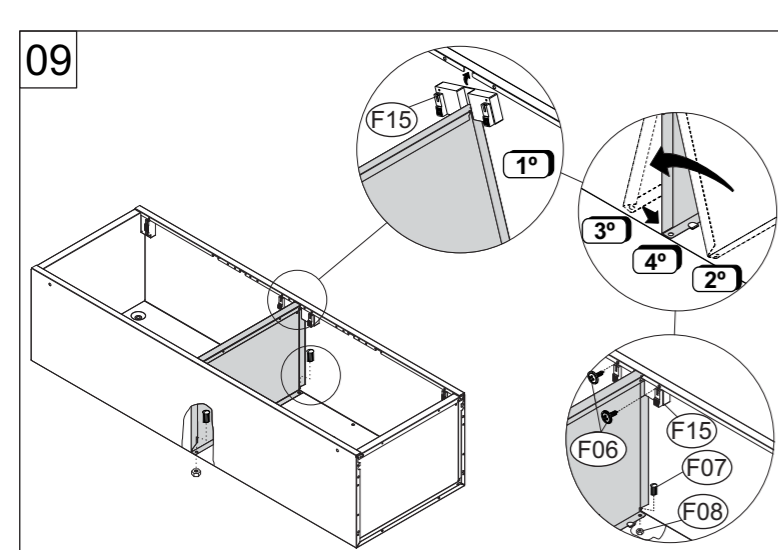

**IMPORTANTE:**  
Para sua segurança, fixe o móvel na parede com o acessório fornecido pela Bertolini. **OBS.:** A Bertolini não se responsabilizará por acidentes decorrentes da não observância desta norma e pela fragilidade da parede.  
**IMPORTANT:**  
For your safety, fasten the cabinet to the wall with the accessory furnished by Bertolini. **NOTE:** Bertolini will not be responsible for accidents resulting from non observing this norm or by the weakness of the wall.  
**IMPORTANTE:**  
Para su seguridad, fije el mueble en la pared con el accesorio suministrado por Bertolini. **OBS.:** Bertolini no se responsabilizará por accidentes ocasionados por la inobservancia de esta norma y por la fragilidad de la pared.